

# 1969 GENERAL MOTORS REAR SEAT SHOULDER STRAP INSTALLATION INSTRUCTIONS ALL CONVERTIBLE STYLES

## ALL STYLES EXCEPT CORVAIR

EXCEPT CHEVROLET IMPALA & CADILLAC DE VILLE

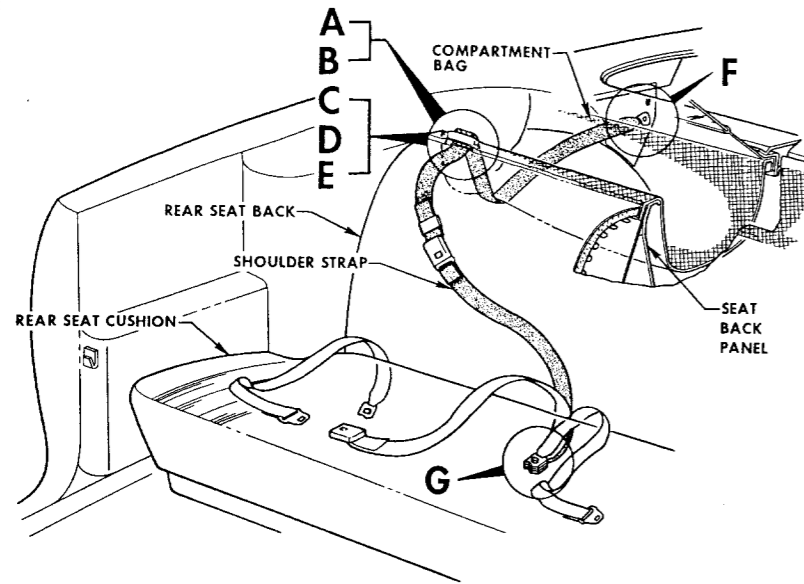

- 1 REMOVE REAR SEAT CUSHION AND REAR SEAT BACK.
- 2 STUDY VIEW C AND CHART CAREFULLY AND MEASURE INWARD FROM THE END OF REAR SEAT BACK PANEL DISTANCE X AND DRILL A 1/8" DIA. HOLE THRU COMPARTMENT BAG AND SEAT BACK PANEL. MEASURE OUTWARD FROM THE ABOVE DESCRIBED HOLE DISTANCE Y AND DRILL A SECOND 1/8" DIA. HOLE. SLIT COMPARTMENT BAG APPROXIMATELY 1/2" OUTWARD FROM EACH HOLE AS SHOWN IN VIEW C AND LOOSEN MATERIAL FROM FRONT EDGE OF SEAT BACK PANEL.
- 3 TURN UNDER LOOSE MATERIAL AND PLACE BETWEEN COMPARTMENT BAG AND SEAT BACK PANEL AS SHOWN IN VIEW D.
- 4 INSERT SHOULDER STRAP UNDER FOLDED PORTION OF COMPARTMENT BAG AND EXTEND TO ANCHOR PLATE ATTACHING AREA AND INSTALL AS SHOWN IN VIEW F.
- 5 POSITION PLASTIC SLEEVE BETWEEN COMPARTMENT BAG AND SEAT BACK PANEL AS SHOWN IN VIEW E AND INSTALL SCREWS.

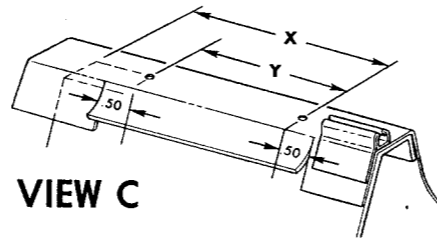

VIEW C

| STYLES                                    | DIMENSION |        |
|---|-----------|--------|
|   | X         | Y      |
| CHEVROLET CAMARO                          | 4 5/8"    | 3 1/2" |
| PONTIAC FIREBIRD                          |           |        |
| CHEVROLET CHEVELLE                        |           |        |
| PONTIAC TEMPEST, LEMANS & GTO             | 5 3/8"    | 3 1/2" |
| OLDSMOBILE F85, CUTLASS & 442             |           |        |
| BUICK SKYLARK & GRAN SPORT                |           |        |
| PONTIAC CATALINA, BONNEVILLE & GRAND PRIX |           |        |
| OLDSMOBILE EIGHTY EIGHT & NINETY EIGHT    | 5 5/8"    | 3 1/2" |
| BUICK LE SABRE, WILDCAT & ELECTRA "225"   |           |        |

## CHEVROLET IMPALA & CADILLAC DE VILLE

- 1 REMOVE REAR SEAT CUSHION AND REAR SEAT BACK.
- 2 MEASURE 3 1/2" OUTWARD FROM THE END SCREW FASTENER AND DRILL A 1/8" DIA. HOLE THRU COMPARTMENT BAG AND SEAT BACK PANEL AS SHOWN IN VIEW A.
- 3 INSERT SHOULDER STRAP BETWEEN COMPARTMENT BAG AND SEAT BACK PANEL AND EXTEND TO ANCHOR PLATE ATTACHING AREA AND INSTALL AS SHOWN IN VIEW F.
- 4 POSITION PLASTIC SLEEVE BETWEEN COMPARTMENT BAG AND SEAT BACK PANEL AS SHOWN IN VIEW B AND INSTALL SCREW.

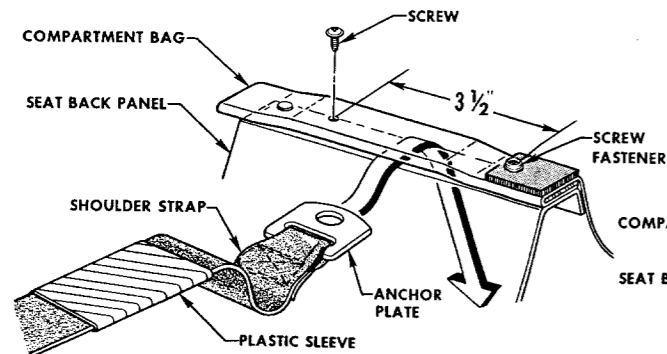

VIEW A

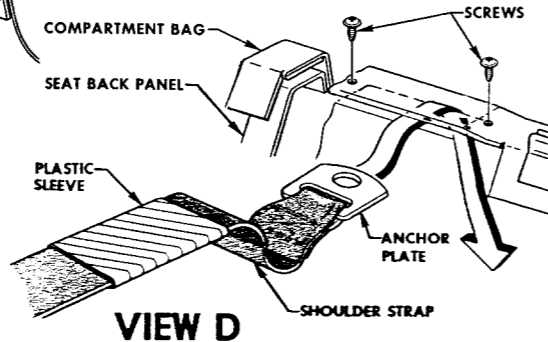

VIEW D

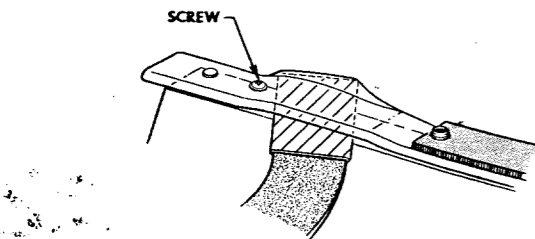

VIEW B

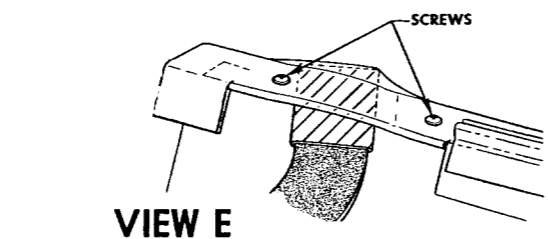

VIEW E

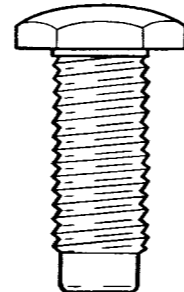

1/2" 13 THREAD  
NO SHOULDER

## CORVAIR STYLES

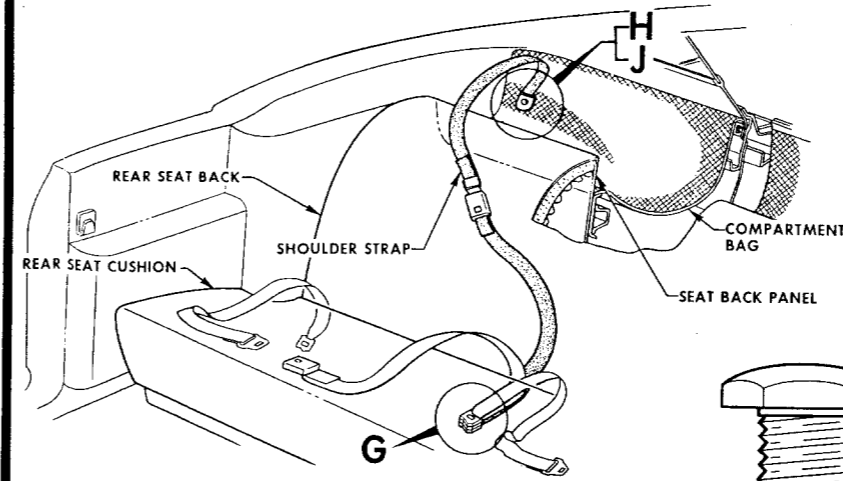

- 1 REMOVE REAR SEAT CUSHION AND REAR SEAT BACK.
- 2 REMOVE FORWARD EDGE OF COMPARTMENT BAG FROM THE SEAT BACK PANEL AND LIFT BAG EXPOSING JOINT OF SIDE AND CENTER FOLDING TOP PANELS.
- 3 LOCATE THE 3/16" DIA. PILOT HOLE USING DIMENSIONS SHOWN IN VIEW H AND DRILL 1/32" DIA. HOLE.  
**NOTE:** IT MAY BE NECESSARY TO REMOVE EXCESS SEALING MATERIAL TO LOCATE PILOT HOLE IN FOLDING TOP SIDE PANEL.
- 4 LOWER COMPARTMENT BAG INTO NORMAL POSITION AND PIERCE HOLE IN BAG ADJACENT TO 17/32" DIA. HOLE IN FOLDING TOP PANELS AS SHOWN IN VIEW J.
- 5 WITH THE AID OF AN ASSISTANT INSTALL SHOULDER STRAP ANCHOR PLATE AND ATTACHING PARTS AS SHOWN IN VIEW J.
- 6 REPLACE FORWARD EDGE OF COMPARTMENT BAG TO SEAT BACK PANEL IN ITS ORIGINAL POSITION. (NOTE: TRIM CEMENT IS AVAILABLE AT YOUR G.M. DEALER.)

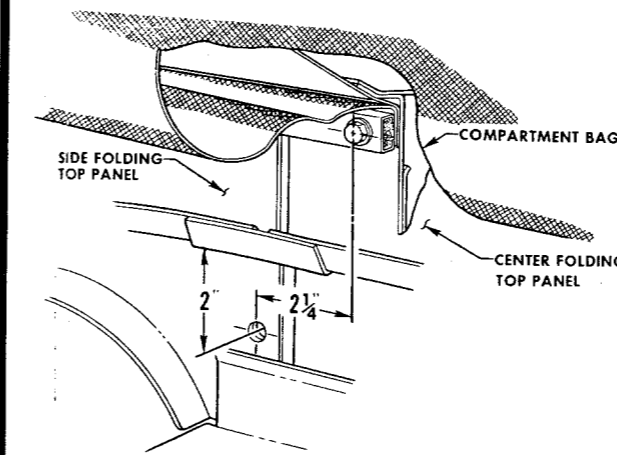

VIEW H

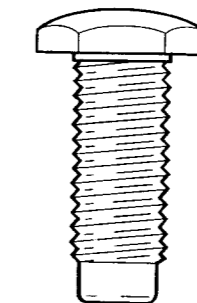

1/2" 13 THREAD  
NO SHOULDER

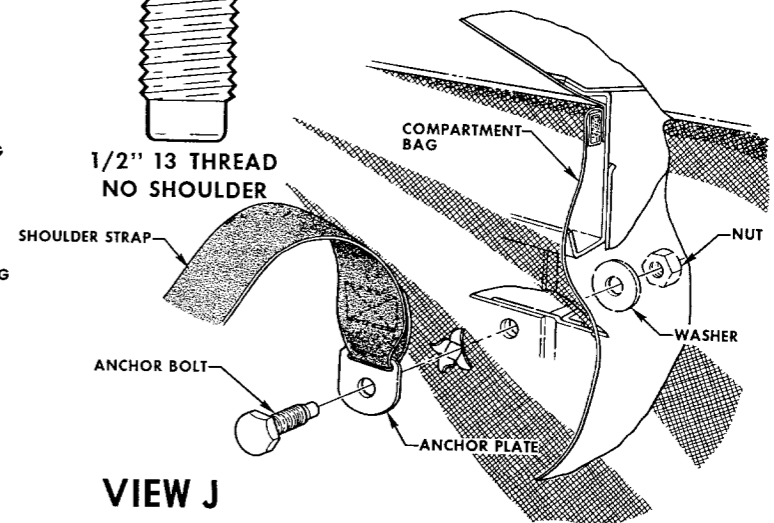

VIEW J

## QUARTER ANCHORAGE

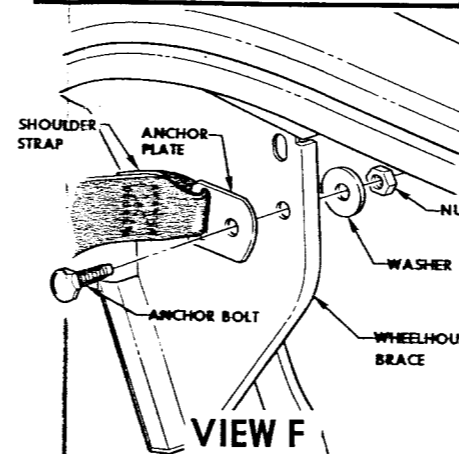

VIEW F

ALL STYLES EXCEPT CORVAIR

WORKING THRU LUGGAGE COMPARTMENT LOCATE THE WHEELHOUSE BRACE. ON SOME STYLES THIS AREA WILL BE FRIMMED REQUIRING REMOVAL OF A HINGE BOX COVER AND THE TURNING BACK OF THE FRONT PORTION OF COMPARTMENT SIDE TRIM PANEL. LOCATE THE 9/16" DIA. PIERCED HOLE IN THE WHEELHOUSE BRACE AND INSTALL SHOULDER STRAP ANCHOR PLATE AS SHOWN IN VIEW F.

**NOTE:** FOR INSTRUCTIONS ON REMOVAL AND INSTALLATION OF ALL SEAT CUSHIONS, SEAT BACKS AND TRIM PANELS NECESSARY TO PERFORM OPERATIONS DESCRIBED ON THIS SHEET, REFER TO 1969 COPY OF THE FISHER BODY SERVICE MANUAL AVAILABLE AT YOUR GM DEALER.

## FLOOR ANCHORAGE

- 1 MAKE FLOOR ANCHORAGE ACCESSIBLE.
- 2 REMOVE EXISTING ANCHOR BOLT AND DISCARD.
- 3 INSTALL REAR SEAT SHOULDER STRAP AS SHOWN IN VIEW G.
- 4 INSERT NEW LONGER 1/2 INCH X 13 UNC-2A BOLT WITH 9/16 SHOULDER THROUGH BELT ANCHOR PLATES AND SECURE TO FLOOR ANCHORAGE.
- 5 REPLACE REAR SEAT CUSHION.

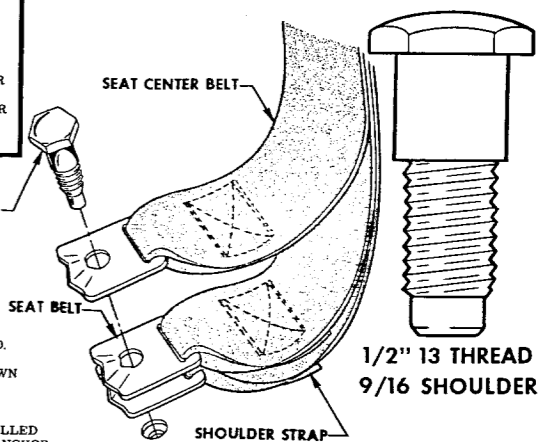

VIEW G  
ALL STYLES

8701739

# FRONT SEAT SHOULDER STRAP INSTALLATION INSTRUCTIONS

## ALL CONVERTIBLE STYLES

### QUARTER ANCHORAGE

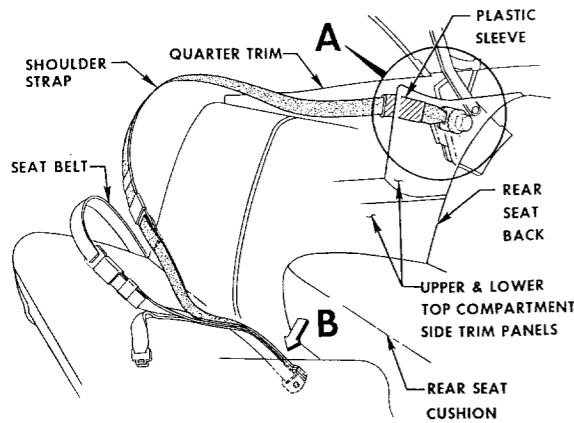

- 1 TO INSTALL FRONT SEAT SHOULDER STRAP TO CONVERTIBLE QUARTER AREA, REMOVE REAR SEAT BACK AND SEAT CUSHION. REMOVE UPPER AND LOWER TOP COMPARTMENT SIDE TRIM PANELS.
- 2 EXAMINE VIEW A CAREFULLY. LOCATE SPECIFIC BOLT USED IN YOUR CAR OR LOCATION OF NEW BOLT, IF APPLICABLE.
- 3 REMOVE EXISTING HINGE ANCHOR BOLT WHEN NECESSARY.
- 4 SECURE SHOULDER STRAP TO HINGE SUPPORT AS SHOWN WITH EXISTING OR NEW ANCHOR BOLT.
- 5 INSTALL UPPER AND LOWER TOP COMPARTMENT SIDE TRIM PANELS MAKING SURE THAT THE PROTECTIVE SLEEVE IS POSITIONED BETWEEN SIDE TRIM PANELS AND QUARTER TRIM.

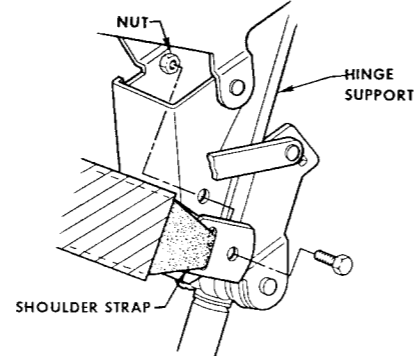

CHEVROLET IMPALA  
PONTIAC CATALINA, GRAND PRIX & BONNEVILLE  
OLDSMOBILE EIGHTY EIGHT & NINETY EIGHT  
BUICK LA SABRE, WILDCAT, & ELECTRA "225"  
CADILLAC DE VILLE

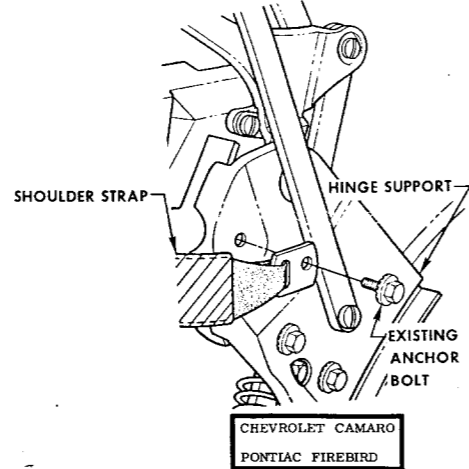

CHEVROLET CAMARO  
PONTIAC FIREBIRD

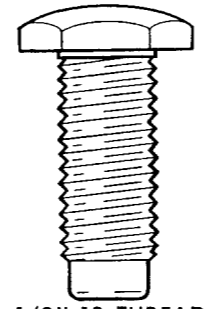

1/2" 13 THREAD  
NO SHOULDER

VIEW A

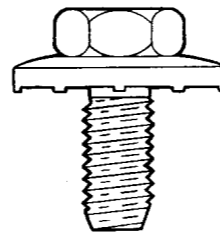

3/8" 16 THREAD

VIEW A

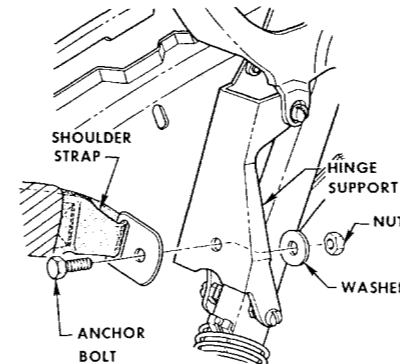

CHEVROLET CHEVELLE  
PONTIAC TEMPEST, LEMANS & GTO  
OLDSMOBILE F85, CUTLASS & 442  
BUICK SKYLARK & GRAN SPORT

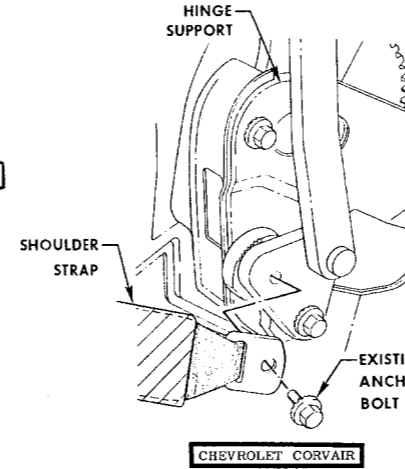

CHEVROLET CORVAIR

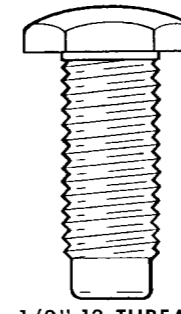

1/2" 13 THREAD  
NO SHOULDER

VIEW A

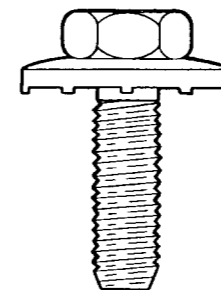

3/8" 16 THREAD

VIEW A

### FLOOR ANCHORAGE

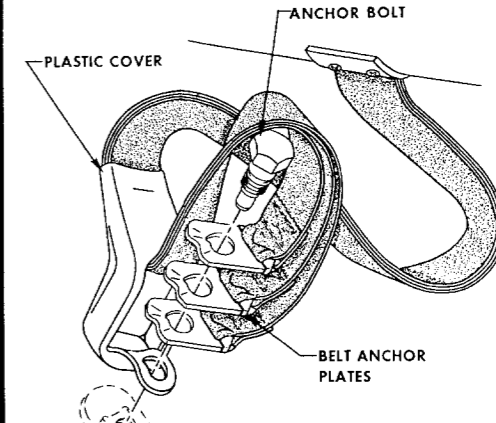

- 1 REMOVE EXISTING ANCHOR BOLT.
  - 2 INSTALL FRONT SEAT SHOULDER STRAP AS SHOWN IN VIEW B.
- NOTE:** CHECK POSITION OF FACTORY INSTALLED BELT ANCHORS AND INSTALL NEW BELT AND ANCHOR PLATES IN SAME POSITION. CARE MUST BE EXERCISED WHEN MAKING INSTALLATION THAT ALL BELT ANCHOR PLATES INTER-LOCK AS SHOWN.
- 3 ON BUCKET TYPE SEAT REPLACE EXISTING ANCHOR BOLT THROUGH BELT ANCHOR PLATES AND SECURE TO FLOOR. ON BENCH TYPE SEAT USE NEW 1/2 INCH X 13 UNC - 2A BOLT WITH 13/16" SHOULDER PROVIDED.

**NOTE:** FOR INSTRUCTIONS ON REMOVAL AND INSTALLATION OF ALL SEAT CUSHIONS, SEAT BACKS AND TRIM PANELS NECESSARY TO PERFORM OPERATIONS DESCRIBED ON THIS SHEET, REFER TO 1969 COPY OF THE FISHER BODY SERVICE MANUAL AVAILABLE AT YOUR G.M. DEALER.

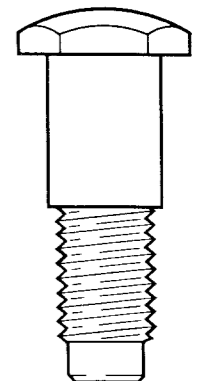

1/2" 13 THREAD  
13/16" SHOULDER

VIEW B

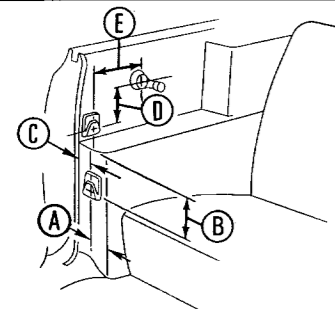

#### NOTE-

- 1 EXAMINE THIS SHEET CAREFULLY, AND LOCATE THE STYLE AND DIMENSION FOR LOCATING THE RETAINER IN YOUR CAR.
- 2 DRILL TWO (2) 1/8" HOLES AND SECURE RETAINER TO BODY.

### BUCKLE RETAINER

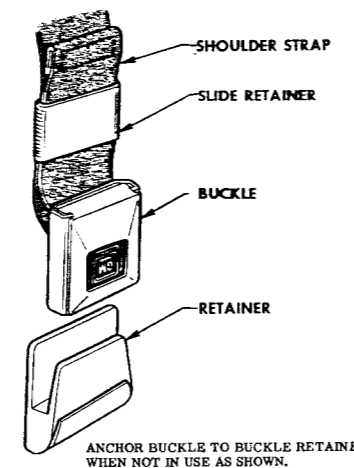
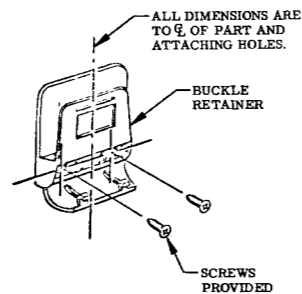

ANCHOR BUCKLE TO BUCKLE RETAINER WHEN NOT IN USE AS SHOWN.

| STYLES                                    | DIMENSION |        |   |       |       |
|---|-----------|--------|---|-------|-------|
|   | A         | B      | C | D     | E     |
| CHEVROLET CAMARO                          | 4         | 6 1/2  |   |       |       |
| PONTIAC FIREBIRD                          |           |        |   |       |       |
| CHEVROLET CHEVELLE                        |           |        |   |       |       |
| PONTIAC TEMPEST, LEMANS & GTO             | 3 1/8     | 8 1/4  |   |       |       |
| OLDSMOBILE F85, CUTLASS & 442             |           |        |   |       |       |
| BUICK SKYLARK & GRAN SPORT                |           |        |   |       |       |
| CHEVROLET IMPALA                          |           |        |   |       |       |
| PONTIAC CATALINA, BONNEVILLE & GRAND PRIX | 2 7/16    | 8 3/8  |   |       |       |
| OLDSMOBILE EIGHTY EIGHT & NINETY EIGHT    |           |        |   |       |       |
| BUICK LA SABRE, WILDCAT & ELECTRA "225"   |           |        |   |       |       |
| CADILLAC DE VILLE                         |           | 11 1/8 | 2 |       |       |
| CHEVROLET CORVAIR MONZA                   |           |        |   | 5 1/8 | 4 7/8 |

### BELT ADJUSTMENT

DELUXE BUCKLE SHOWN STANDARD TYPICAL

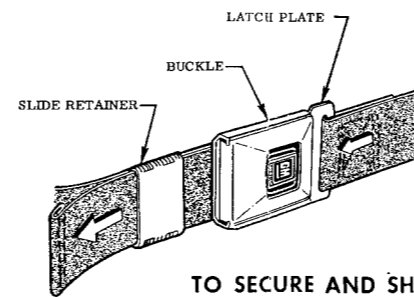

TO SECURE AND SHORTEN

WITH BUCKLE SECURE, ADJUST THE BELT FIRMLY TO YOUR HIPS BY PULLING ON THE LOOSE END OF WEBBING PROTRUDING FROM THE BUCKLE.

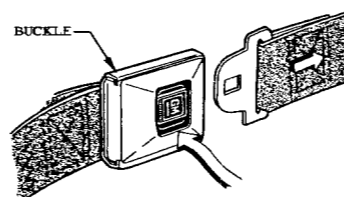

TO UNLATCH

TO RELEASE BELT, DEPRESS BUTTON ON BUCKLE.

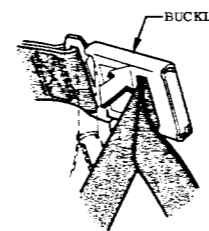

TO LENGTHEN

TO ENLARGE THE BELT, LIFT BUCKLE APPROXIMATELY 90 DEGREES TO THE WEBBING AND PULL ON BUCKLE TO DESIRED LENGTH.

### GENERAL INFORMATION

THIS UPPER TORSO RESTRAINT IS TO BE USED ONLY IN CONJUNCTION WITH A LAP BELT. NEVER USE THE SHOULDER STRAP ALONE.

SHOULDER STRAPS NOT IN USE MUST BE ANCHORED BY INSERTING BUCKLE INTO RETAINER LOCATED ON BODY PILLAR TO PREVENT BUCKLE END LASHING ABOUT.

SHOULDER STRAPS ARE RECOMMENDED ONLY FOR PERSONS OVER 4 FEET 7 INCHES IN HEIGHT.

PROPER USE AND CARE OF YOUR SHOULDER STRAPS AND SEAT BELTS WILL PROVIDE ADDED SECURITY TO DRIVER AND PASSENGERS.

- 1 INSERT THE LATCH PLATE INTO THE OPEN END OF THE BUCKLE UNTIL AN AUDIBLE SNAP IS HEARD.
- 2 ADJUST BELT BY PULLING ON THE LOOSE END OF WEBBING PROTRUDING FROM THE BUCKLE.  
SEAT BELTS SHOULD BE ADJUSTED FIRMLY, LOW ON THE HIPS. SHOULDER STRAPS SHOULD HAVE SUFFICIENT SLACK TO ALLOW A HAND'S WIDTH TO BE INSERTED FREELY BETWEEN THE BELT AND CHEST.
- 3 TO ENLARGE THE BELT, TILT BUCKLE TO APPROXIMATELY 90 DEGREES TO THE WEBBING AND PULL ON BUCKLE TO DESIRED LENGTH.
- 4 KEEP SHARP EDGES AND DAMAGING OBJECTS AWAY FROM BELTS.

#### NOTE: AVOID THE FOLLOWING CONDITIONS

- a. WEARING SEAT BELTS LOOSELY OR SHOULDER STRAPS SNUG
- b. BLEACHING OR RE-DYEING WEBBING (CLEAN WITH A MILD SOAP SOLUTION AND WATER)
- c. MORE THAN ONE PERSON PER BELT SET (SEAT & SHOULDER)
- d. WEARING A TWISTED BELT

### ATTENTION DEALERS

PLACE THIS INSTRUCTION SHEET IN GLOVE BOX AFTER BELT INSTALLATION.

**1969**

**FRONT & REAR SEAT SHOULDER STRAP INSTALLATION INSTRUCTIONS**

CONVERTIBLE

FISHER BODY ENGINEERING ACTIVITY

**8701739**